



OPERATING INSTRUCTIONS

(Translation)



Rope winch

Type	KWE 250	KWV 300
	KWE 650	KWV 650
	KWE 1000	KWV 1250

1. USER GROUPS

	Duties	Qualifications
Operator	Operation, visual inspection	Instruction by means of the operating instructions; Authorised person 1
Specialist personnel	Assembly, disassembly, repair, maintenance	Mechanic
	Tests	Authorised person 2 per TRBS-1203a (Technical expert)

2. SAFETY INSTRUCTIONS

Appropriate use

Operate the equipment in accordance with the information in these operating instructions.

- Only use to lift, lower and pull freely-movable loads.
- Only use when in perfect working order.
- Only allow to be operated by personnel instructed on how to do so.

Safety-conscious work

- First read the operating instructions.
- Always be conscious of safety and hazards when working.
- Observe lifting device and load during all movements.
- Immediately report any damage or defects to the person in charge.
- Repair equipment first before continuing work!

The following are not allowed:

- Overload (--> technical data, type plate, payload plate)
- Mechanical propulsion.
- Impacts, blows.

Use exclusions

- Not suitable for permanent operation and vibration stress.
- Not approved for use as builders' hoist (BGV D7).
- Not approved for use on stages or in studios (BGV C1).
- Not approved for use as a retractable transportation device for personnel (BGR 159).
- Not approved for use in explosive areas/environments.
- Not suitable for aggressive environments.
- Not suitable for lifting hazardous loads.

Organisational measures

- Ensure that these operating instructions are always at hand.
- Ensure that only trained personnel work with the equipment.
- Check at regular intervals whether it is being used in a safety and hazard conscious manner.

Installation, service and repair

Only by specialist personnel!

Only use original spare parts for repairs.

Do not modify or alter safety-relevant parts!

Additional attachments must not impact safety.

Further regulations to be observed are

- German Industrial Health and Safety Ordinance (BetrSichV).
- Country-specific regulations.
- German Accident prevention regulations (BGV D8).

Load

- Do not leave suspended without supervision.
- Do not allow to swing.
- Do allow to fall in the rope.

Rope

- Compliant with EN 12385-1 and EN 12385-4 and the technical data
- Maintain rope deviation angle
 - non-rotating rope $\leq 3^\circ$ (standard)
 - rotation-resistant rope $\leq 1.5^\circ$
- Use a rotation-resistant rope for unguided loads. This can reduce the resting period of the rope (drive mechanism group).



Wear on the rope is reduced if the rope is fully unwound in an unloaded state and then wound back up in layers while under load.



The length of the rope is correct if:

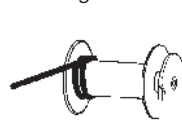

> 2

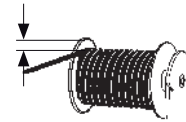
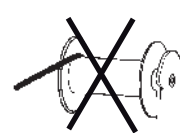

> 1.5 x rope Ø

Lifting equipment

- Ensure sufficient load-bearing capacity.
- Only use load hooks with a safety flap.
- Use the approved load hooks with rope thimbles and rope clip.
- Attach the load properly.
- Do not use the winch rope to secure the load.

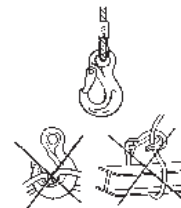

3. TECHNICAL DATA

Type		KWE	KWV	KWE	KWV	KWE	KWV
Nominal load [kg]		250	300	650	650	1000	1250
1 st Layer	W.L.L [kg]	250	300	650	650	1000	1250
	Storage [m]	3,4	2,8	3,4	3,2	3,4	3,2
max. no. of layers		6	6	6	7	9	9
Last layer	W.L.L [kg]	125	150	340	330	390	490
	Storage [m]	22	22	16	23	28,5	28,5
Rope Ø [mm]		4	4	7	6	8	8
FEM Rating ¹		1Em	1Em	1Em	1Em	1Em	1Em
Breaking load [kN]		7,4	8,9	19,2	19,2	29,5	36,8
Crank force [N]		220	270	250	240	200	240
Weight [kg] w.o. rope		3,9	3,9	6,3	5,9	16	16

1) FEM Rating according to DIN 15020 resp. FEM 9.511 for ordinary rope

4. GENERAL

The hand winches are drum type winches. They are driven by a single reduction pair of straight cut internal spur gear or direct. The load is safely supported in any position by means of an automatic mechanical brake.

5. MOUNTING

- the mounting structure must be designed to sustain the max forces imposed by the winch
- pay careful attention that the mounting surface is flat and true
- use always 4 screws size M10 (min. quality 8.8)
- tighten the screws evenly and secure screws
- ensure that the crank is free running (crank clearance).

6. ROPE MOUNTING



With wrong rope coiling the brake is not effective!

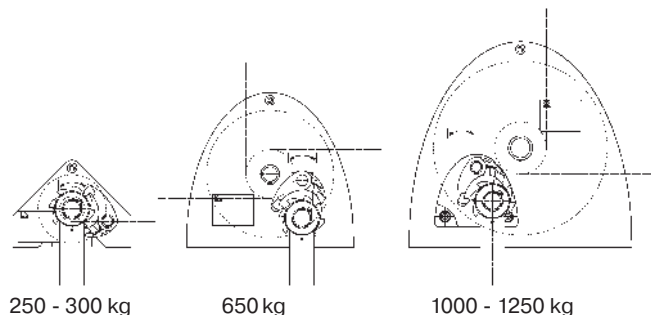

Wire rope fixing



Grease slightly the drum, before fixing the wire rope.

Recommended ropes:

- Ordinary ropes, zinc plated
EN 12385, Tab. 12, 6x19 WC 1770 B sZ (former DIN 3060 SE znk 1770 sZ)
- Ordinary ropes, stainless steel:
similar to EN 12385. 7 x 19
[former DIN 3060 SE bk 1570 sZ (1.4401)]
Rope diameter and breaking load see point 3
It is not allowed to use plastic coated ropes.

Hard solder the rope end clamp to the rope drum with a hexagonal wrench (SW 4 with 6 Nm, SW 5 with 5 Nm) (fig 1 and fig. 2). After rotating the crank in clockwise direction, the rope must reel up on the drum as illustrated in fig. 3.

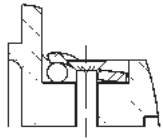

fig. 1

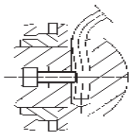

fig. 2

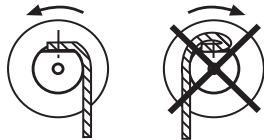

fig. 3



A functional test must always be accomplished before beginning work.

7. OPERATION

Lift the load: Turn crank clockwise.

Lower the load: Turn crank anti-clockwise.

If the crank is not turned the load is suspended safely. When lifting a load, do not wind rope beyond the point where at least 1,5 x rope diameter is left free on drum flanges above outermost layer.

When loaded, at least 2 turns of the rope must remain on the drum. The capacity of the first layer corresponds to the nominal capacity of the winch. This means that the capacity decreases with every further layer (refer to type-/ capacity number plate for capacity of first and last layer).

Version with crank to declutch rope drum (option)



Only for unloaded rope.

Declutchable rope drum:

- Push crank arm towards the rope winch. The coupling pins move out of the coupling disc. Unloaded rope can be pulled off.

Clutch in:

- Pull and turn crank until the coupling pins engage into the coupling disc.

Version with adjustable crank arm (option):

- Loosen wing screw, adjust crank radius, tighten wing screw.

8. INSPECTION

The equipment must be inspected in accordance with the conditions of use and the operating conditions at least once per year by an authorised person 2 per TRBS 1203 (Technical expert) (testing per BetrSichV, §10, sect.2 represents implementation of EC Directives 89/391/EEC and 95/63/EC and the annual occupational safety inspection per BGV D8, §23, sect. 2 and BGG956). These inspections must be documented:

- Before commissioning.
- After significant alterations before recommissioning.
- At least once per year.
- In the event of unusual occurrences arising that could have detrimental effects on the safety of the winch (extraordinary tests, e.g. after a long period of inactivity, accidents, natural events).
- After repair works that could have an influence on the safety of the winch.

Technical experts (AP2) are persons, who have sufficient knowledge based on their specialist training and experience, in the areas of winches, lift and pull systems and the relevant official occupational health and safety rules, accident prevention regulations, guidelines and generally accepted engineering rules (e.g. EN standards), to evaluate the operational safety of winches, and lift and pull systems. Technical experts (AP2) are to be nominated by the operator of the equipment. Performance of the annual occupational safety inspection as well as the training required to obtain the aforementioned knowledge and skills can be provided by haacon hebetechnik.

9. MAINTENANCE RECOMMENDATION

The operator determines the intervals themselves based on frequency of use and the operating conditions.

- Regular cleaning, no steam jets!
- Carry out visual check on inaccessible brakes / locks every 5 years at the latest, replace brake pads as required.
- General overhaul by the manufacturer after 10 years at the latest.



CAUTION!

Only perform inspection, maintenance and repair work on an unloaded hoist. Only allow work on brakes and locks to be performed by qualified specialist personnel.

Maintenance and inspection work	Intervals
Visual check of the rope hooks (load carrier)	Before every use
Function of the winch	
Condition of the rope and lifting equipment	
Brake function under load	
Grease bearing of drive pinion	Quarterly Annually
Check rope for wear acc. to DIN 15020 Sheet 2 and service	
Check fastening bolts for secure seating	
Check all parts of the winch and crank for wear, if applicable, replace defective parts and lubricate.	Annually
Check type plate for legibility	
Have an inspection performed by an expert	

Lubricant recommendations: Multi-purpose grease per DIN 51502 K3K-20

Safety crank

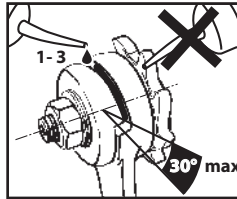

If sluggishness occurs during lowering, pour a few drops of oil into the gap in the crank cam. Safety cranks with a gap aperture >30° should be replaced. Repair must be carried out by only by the manufacturer.



CAUTION!

Only disassemble the crank, ratchet brace and locking pawl when the equipment is not under load!

Do not oil or grease the brake pads!

10. OPERATION FAILURES AND THEIR CAUSES

Failure	Cause	Elimination
In unloaded state, it is difficult to turn the crank	Lubricant in bearing points is missing. Dirt or something similar has accumulated in the bearing	Execute maintenance works
	Winch was distorted during mounting.	Check the fixing. Is the mounting surface even, are the screws tightened correctly
Load is not held	Wrong coiling of the rope winding direction for lifting was not correct. The brake is worn-out.	Lay the rope correctly. Check brake parts and replace worn-out parts.
	Too light load	The load has to be at least ca. 20 kg resp. 50 kg
Brake does not release, load may only be lowered with high expenditure of force.	Brake discs or brake mechanism is distorted.	Release the brake by slightly striking against the crank arm with the flat of the hand in lowering direction.

11. SPARE PARTS

When ordering spare parts it is essential to quote:

- The type and serial number of the equipment / item and part number

12. DISASSEMBLY, DISPOSAL

- Make sure to observe the safety instructions.
- Dispose of the equipment and the substances within it in an environmentally responsible manner.

EU Installation Declaration

haacon hebetchnik gmbh
Josef-Haamann-Strasse 6
D-97896 Freudenberg/Main



Manufacturer: haacon hebetchnik gmbh
Josef-Haamann-Strasse 6
D-97896 Freudenberg/Main

Phone +49 (0) 9375 / 84-0
Fax +49 (0) 9375 / 8466

The product

Product name: Hand rope winches

Type:	220	241	421	462	468	4060	4185	4202
	4210	4216	4235	4284	4321	4471	4472	4483
	4491	4585	4751	4821	4843	4862	209480	KWV
	KWE	Tango	WA					

Load capacity range: 0,05 – 3 t

conforms with the basic requirements of the directive **Machines (2006/42/EG)**

Appendix I, article

- 1.1.2 Basic for the integration of safety
- 1.1.3 Materials and products
- 1.1.5 Construction of the machine regarding its handling
- 1.3.2 Risk of breakage during operation
- 1.3.4 Risks by surface, edges and corners
- 1.3.7 Risks caused by moving parts
- 1.3.9 Risk of uncontrolled movements
- 1.7 Information
- 4.1.2 Protective measures against mechanical hazards
- 4.3.3 Machines to lift loads
- 4.4 Operating instructions

The product is an incomplete machine as per machine directive (2006/42/EG). The product must not be taken into operation until it is determined that the machine, in which it is to be installed conforms with the machine directive (2006/42/EG).

If the product is changed significantly, it will lose this conformity declared by the manufacturer.

The manufacturer agrees to submit the specific documentation pertaining to this product to individual state institutions electronically, if so requested.

The specific technical documentation as outlined in Appendix VII Part B were compiled.

Responsible for the documentation: Construction

Signed by:

Freudenberg, 21.12.2010



on behalf of Robert Miltenberger



on behalf of Thed Müller

gb Edition 4; 12/10

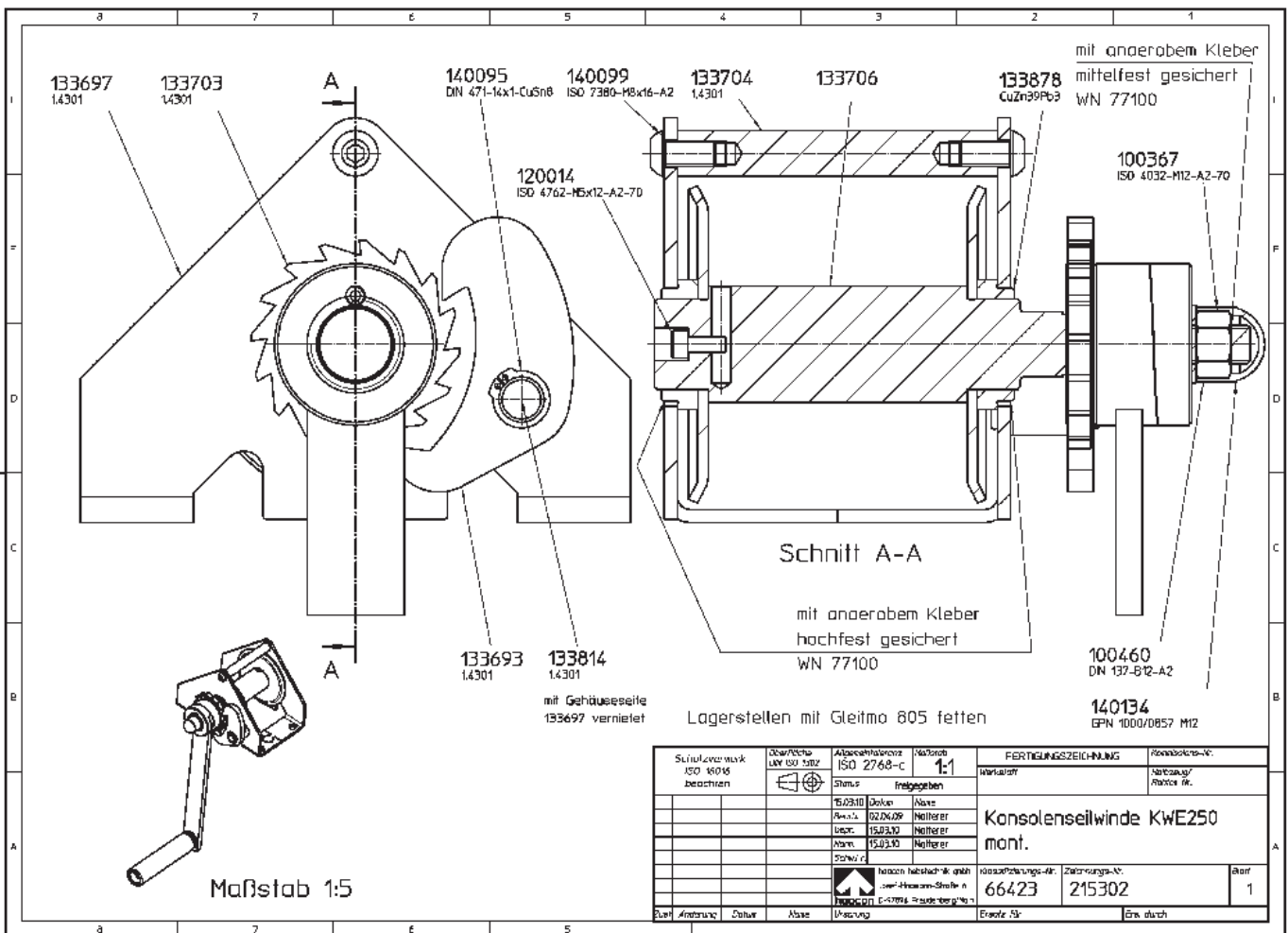
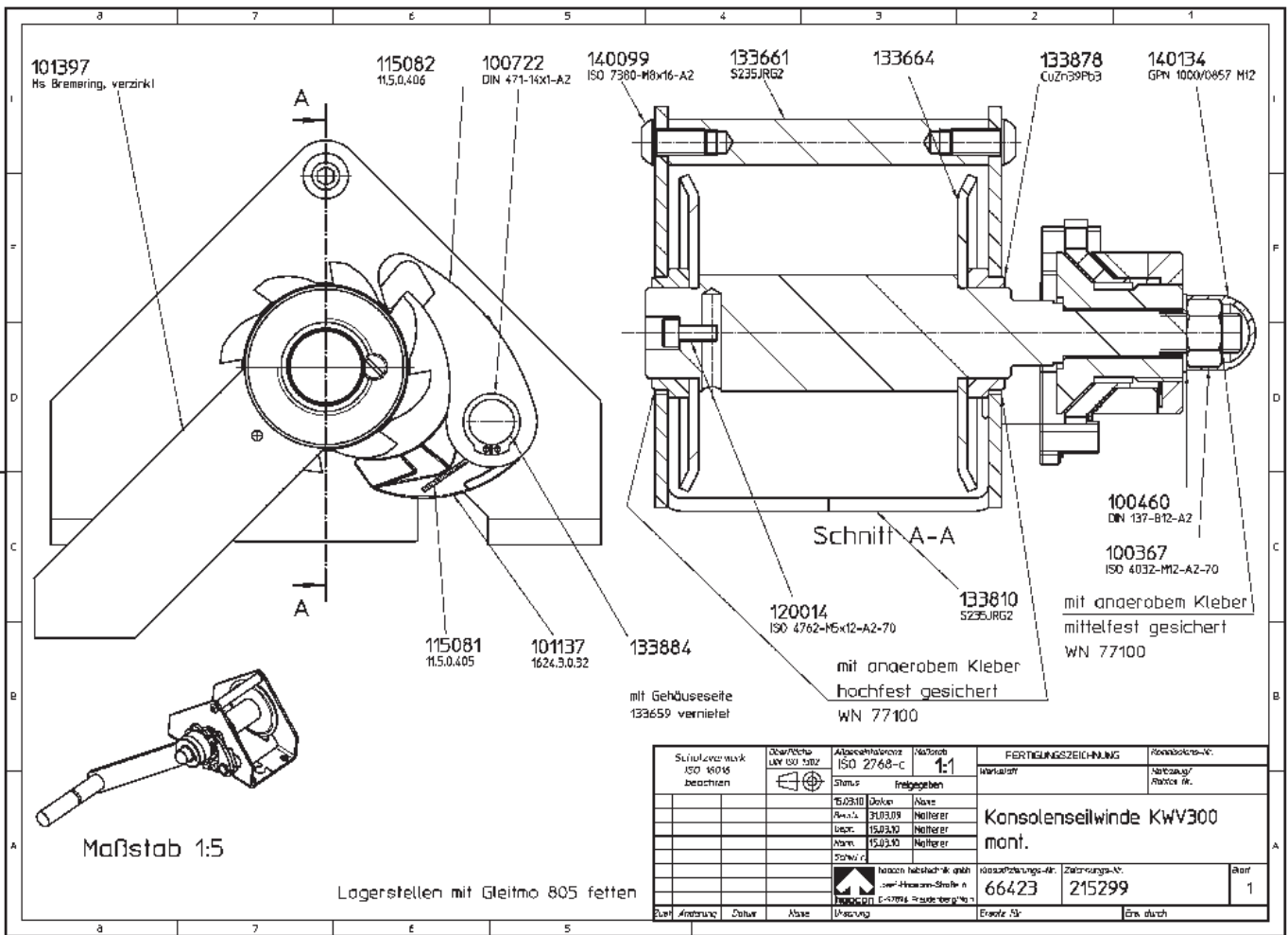
092079 of 21.12.2010

Formblatt-Nr. 100021

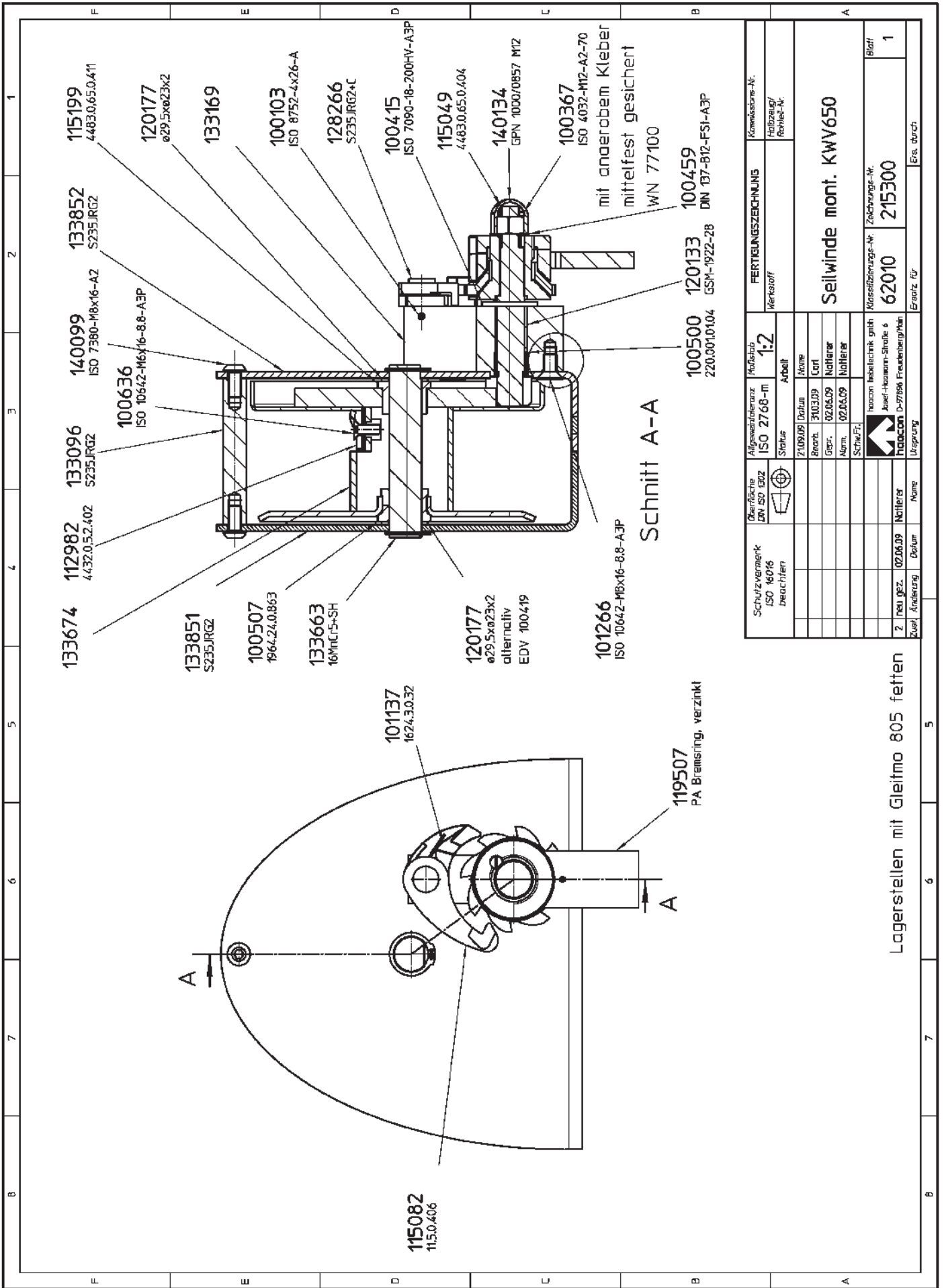



Schutzvermerk ISO 16016 Beachten		Überfläche DIN ISO 1502	Allgemeintoleranz ISO 2768-m	Maßstab 1:2	Kommunikations-Nr. Herstellung/ Reise-Nr.	
Status Arbeit		Zeichner Nottierer	Gepr. 02.06.09	Gepr. 02.06.09	FERTIGUNGSEZEICHNUNG Werkstoff	
Datum 21.09.09		Name Nottierer	Cart	Seilwinde mont. KWV650		
Schw.Fz.		Hacon Hebeltechnik gmbh Josef-Haumann-Str. 6 11000 D-97986 Freutenberghausen		Klassifizierungs-Nr. 215300		
2 neu geg. 02.06.09		Nottierer		Zeichnungs-Nr. 62010		
Zust. Änderung		Datum		Ersatz für		
Name		Ursprung		Ers. durch		
Blatt		1				

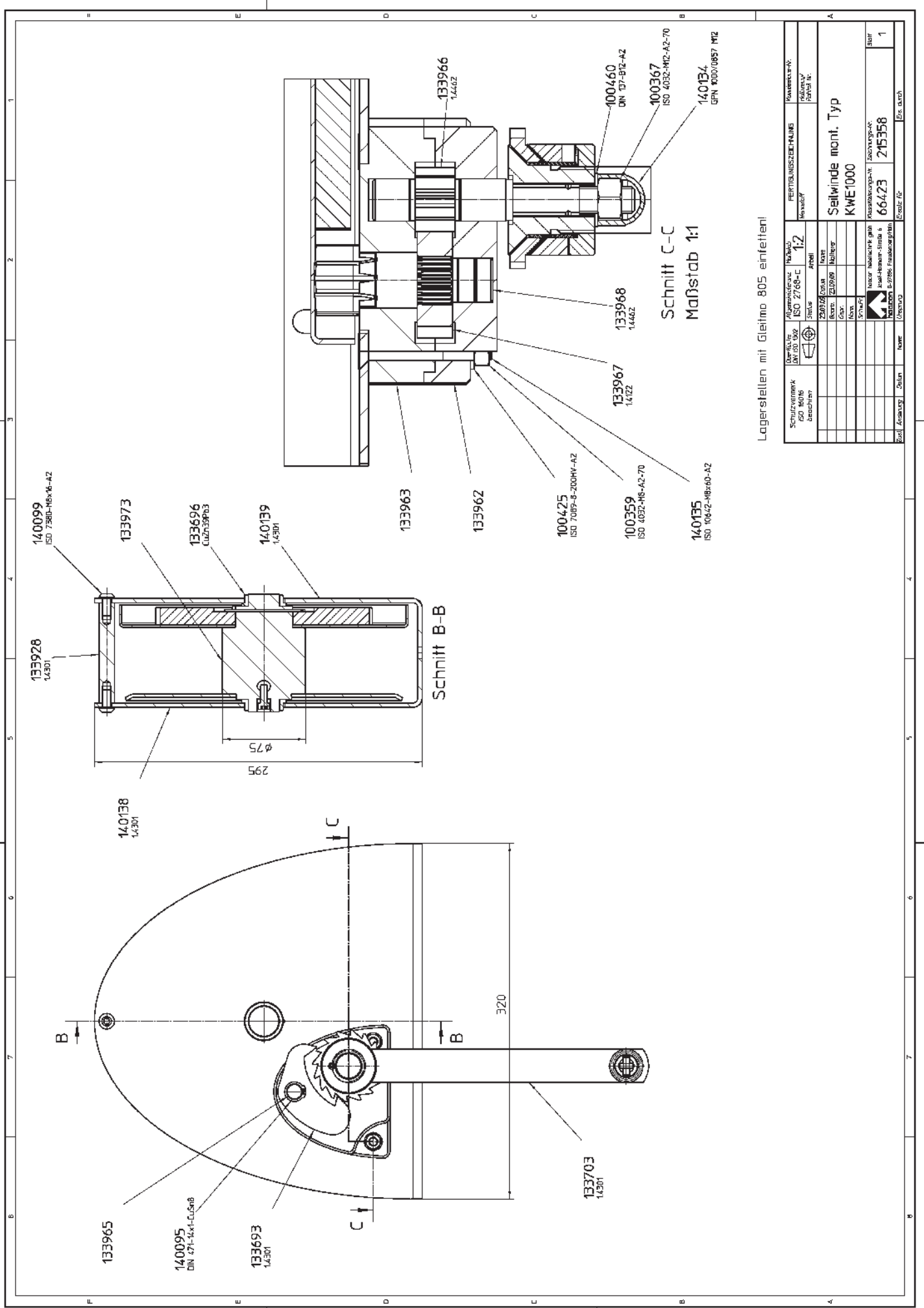

Lagerstellen mit Gleitmo 805 einfetten!

Schutzvermerk ISO 10016 Geotechnik	ISO 2768-C 1,2	FEHRTUNGSZEICHNUNG		Fertigungs-Nr. 140134
		ISO 2768-C	1,2	
ISO 2768-C	1,2	FEHRTUNGSZEICHNUNG		Fertigungs-Nr. 140134
ISO 2768-C	1,2	FEHRTUNGSZEICHNUNG		Fertigungs-Nr. 140134
ISO 2768-C	1,2	FEHRTUNGSZEICHNUNG		Fertigungs-Nr. 140134
ISO 2768-C	1,2	FEHRTUNGSZEICHNUNG		Fertigungs-Nr. 140134
ISO 2768-C	1,2	FEHRTUNGSZEICHNUNG		Fertigungs-Nr. 140134
ISO 2768-C	1,2	FEHRTUNGSZEICHNUNG		Fertigungs-Nr. 140134
ISO 2768-C	1,2	FEHRTUNGSZEICHNUNG		Fertigungs-Nr. 140134
ISO 2768-C	1,2	FEHRTUNGSZEICHNUNG		Fertigungs-Nr. 140134

Seilwinde mont. Typ	20241002-1	20241002-1	20241002-1
KW1000	66423	215358	1
Hersteller-Nr.	66423	215358	1
Seilwinde-Nr.	66423	215358	1
Seilwinde-Mitarbeiter-Nr.	66423	215358	1
Seilwinde-Mitarbeiter-Nr.	66423	215358	1
Seilwinde-Mitarbeiter-Nr.	66423	215358	1